

PANTHER GAS DIRECT PANTHER 400 VENTILLATION INTERLOCK SYSTEM

- Control Panel, Emergency Stop Button & pressure switch-
OPERATION & INSTALLATION MANUAL

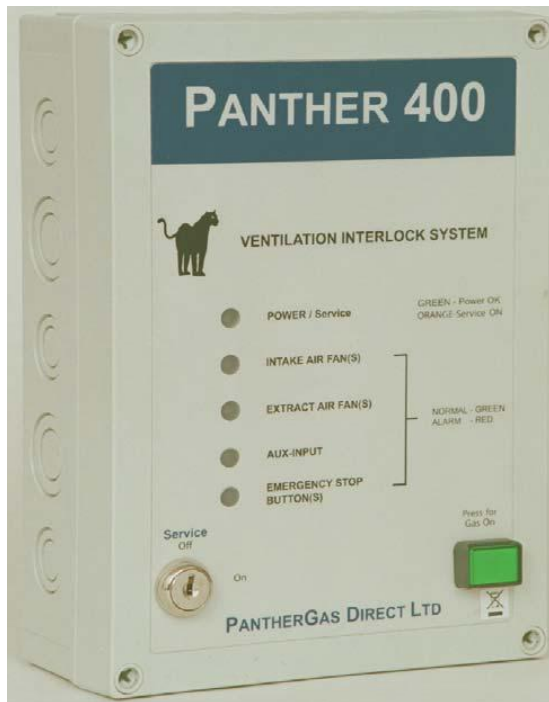

Panther 400 Ventilation Interlock System

The Panther 400 is a four channel ventilation interlock system with key service over-ride for maintenance with coloured status indicators and an independent gas on switch.

The unit has four normally closed independent contact inputs as listed.

1. Intake Fans
2. Extract fans
3. Aux-input
4. Emergency Stop

Each input has an indicator to show the status of the input:

Green – NORMAL

Red - ALARM input state.

Amber- MAINTENANCE

The unit has an indicator for Power ON (Green) - this changes to Amber when the unit is in the "Maintenance Service State".

The unit has a Green Button to turn on the gas supply if the input status is good or the service key switch is in operation.

Each input requires a volt free normally closed contact to show a healthy status on the control panel -green indication.

If all the inputs are healthy then the Gas supply button can be activated- When activated the button will be illuminated.

If any of the input equipment monitored is required to be taken out of service then the unit can be overridden by the service key switch.

If the key switch is switched to "Service" the power indicator will change from

GREEN to AMBER. If required the Gas supply button can be activated to keep the **Gas Supply On.** The Audible alarm remains **ON** in the Service State.

If any input fails then the unit will indicate this by changing the input indicator from **GREEN to RED**

The unit requires a 240vAC supply fused at 3amps + the Gas Valve max current rating. The unit is supplied with a 1 amp fuse for the gas valve but can be up rated if required. **Please ensure that is it not over rated 5 amps MAX.**

OPERATION

1. When installed and the monitored input equipment is running the Four Input Indicators will show: **GREEN**
2. If an input is **not** required then the supplied shorting link should **NOT** be removed.
3. The power indicator should be showing **GREEN –NORMAL**.
If all inputs are indicating Green-**the Green Gas On button can be pushed to enable the Gas valve.**
4. If any of the monitored equipment should fail then the input indicator will show :-
RED & “Gas On” indicator will be OFF.
5. The Service Key switch can be switched over to the Service position to **OVER-RIDE** the failed input. The Power indicator will show: **amber**
The Green “Gas On” button can be pushed to enable the Gas valve.
Note that if any of the monitored equipment fails when the Service Switch is in operation the GAS VALVE WILL NOT DROP OUT except if the 1111Emergency-Stop button is manually activated.

INSTALLATION:

1. The controller is mounted to the wall by removing the front cover. The screws are placed in the corners in the back half of the control box.
2. A 240 volt supply is required via a fuse switched spur; this should be wired to the 240 Volt in terminals on the far right of the PCB. LNE (Live, neutral and earth)
3. Check which inputs are required to be used. If any of the inputs are not required leave the shorting link in place.
4. The Panther 400 wiring schematic clearly shows terminals 1-8 for the supply/extract fans, auxiliary input and emergency stop button connections. The gas valve connections are marked on the PCB as is the main input supply, both with LNE (live, neutral and earth)
5. The 8 terminals on the top left of the controller are the input terminals and should be wired from normally closed volt free contacts across each pair. If an input is not connected across the terminals the link should remain in place

Panther 400 Wiring Schematic

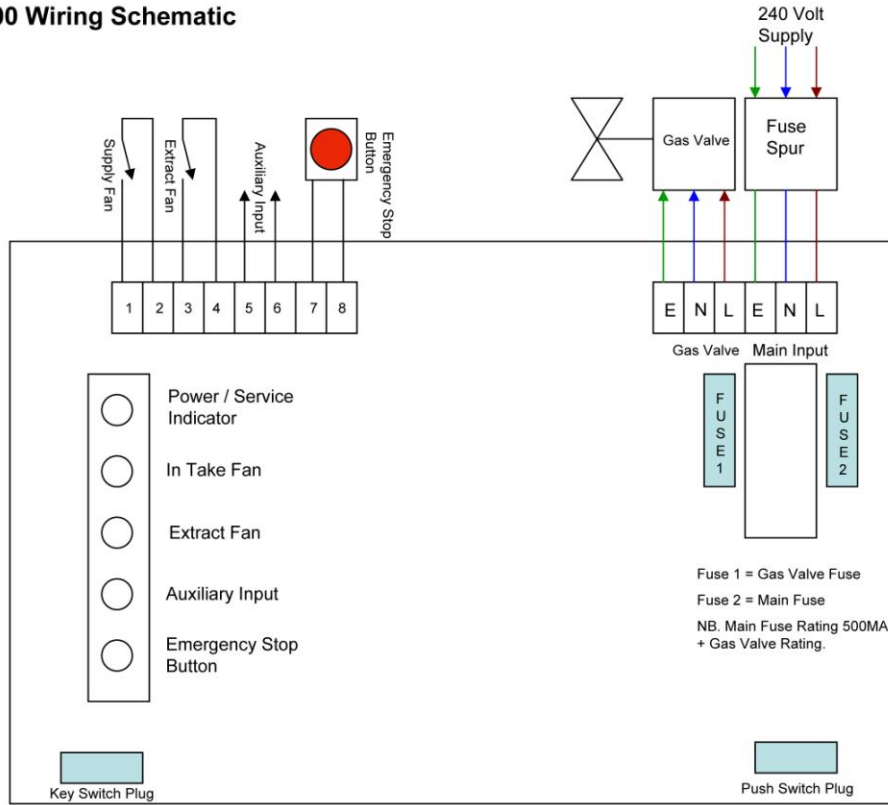

Notes: All input are Volt Free
E-Stop contacts must be Closed

Differential Pressure Switches DPS-Series

FOR AIR CONDITIONING/VENTILATION – USER ADJUSTABLE

PRODUCT DATA

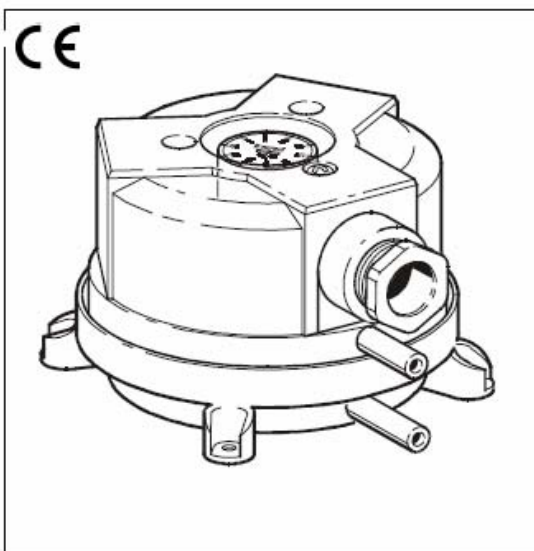

Operating ranges

type	adjustment range for upper trip pressure from to	switching difference (hysteresis)
DPS 200	20 – 200 (Pa)	10 (Pa)
DPS 400	40 – 400 (Pa)	20 (Pa)
DPS 1000	200 – 1000 (Pa)	100 (Pa)
DPS 2500	500 – 2500 (Pa)	150 (Pa)

The trip pressure refers to vertical mounting. In case of horizontal mounting (with cover position upwards) the range values increase by 20 Pa.

Arrangement of contacts

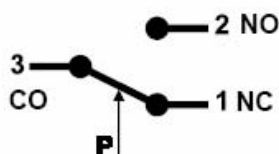

Switch off power before removing cover!

Applications

Differential pressure switch e.g. for monitoring filter, fan, fire damper or air flow status of air handling systems.

Benefits

- Switching point easily adjustable with scale in Pascal
- Direction of PG 11 conduit entry rotatable in steps of 120°
- Only one screw needed for housing cover

Pressure medium

Air, non-inflammable and non-aggressive gases

Specifications

Max. operating pressure:	5000 Pa
Pressure connections:	2 plastic tubes Ø 6.0 mm outside.
Switching capacity:	1.5 A (0.4)/250 V~
Electrical connections:	AMP connectors 6.3 x 0.8 DIN 46244 or screw terminals
Conduit entry	PG 11
Protection class:	IP 54
Mounting lugs:	integrated in bottom housing
Medium/ambient temp.:	- 20 °C – + 85 °C
Storage temperature:	- 40 °C – + 85 °C
Membrane material:	Silicone

Approvals

approval according to low voltage directive EEC 73/23.

Switch according to VDE 0630.

EN-1854.

Accessories

- DPSK* Duct Kit, including 2 m of silicone-hose and 2 joining pipes DPSJ with screws.*
- DPSL Mounting brackets L-shaped
- DPST* Set of 3 push-on screw terminals for AMP connectors.*

* Included in delivery of single package

Dimensions

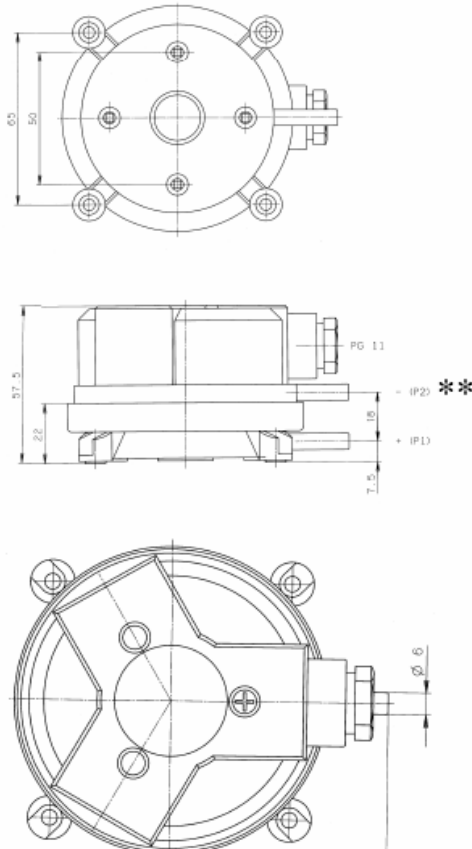

Pressure Switch DPS-Series

- Different cover positions possible
- Cable fitting removable for installation

* Use 2 screws only for mounting lugs!
 ** Remove transport protection from P2!
 Don't install upside down with trip pressures < 50 Pa!

P1 higher pressure
 P2 lower pressure

Options / Accessories

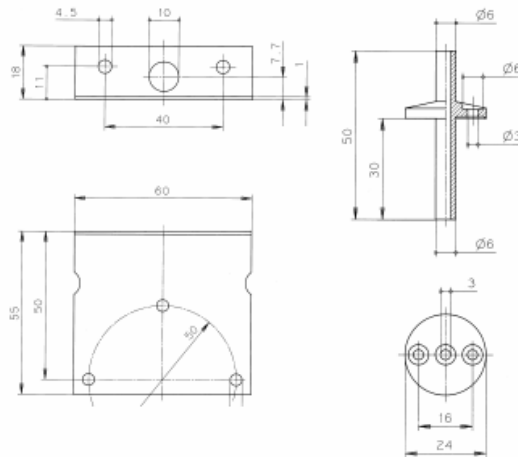

DPSL
 L-shaped mounting brackets



DPST Screw Terminal

Joining pipe, DPSJ
 L-shaped mounting brackets
 (part of DSPK duct kit)

Content of delivery (for single package)

- 1 **DPS** Differential Pressure Switch
- 1 **Data Sheet** with installation information
- 1 **DPS kit** consisting of:
 2 m of silicon hose,
 2 joining pipes DPSJ with 4 screws,
 2 self tapping screws for mounting of housing
 3 terminal screws for electrical installation

Optional accessories

DPSL L-shaped mounting bracket,
 for e.g. vertical installation below ceilings
 including 2 screws

Bulk package available on request

MAINTENANCE:

All Items should be tested on a regular basis and at least every six months.

Test gases are available for gas detector tests.

All items in kitchens should be regularly be cleaned with to ensure dirt and cooking fats do not impair the product performance. **DO NOT** use cleaning sprays.