

PANTHERCUB

User & Installation Manual



Panthergas Direct Ltd, Unit D4 Seedbed Business Centre, Vanguard Way,
Shoeburyness, Essex, SS3 9QY Tel - 01702 384038 Fax - 01702 384043
sales@panthergasdirect.com

IMPORTANT NOTICE

All the items listed in this document - should only be installed by a competent and approved person(s) and all current regulations for Gas and Electrical Regulations **MUST be adhered to. Attention is drawn to Regulations relating to the isolation and reinstatement of Gas and Electrical Systems.**

Isolate the Mains current before starting installation.

MAINTENANCE:

All Items should be tested on a regular basis and in accordance with standard Health & Safety requirements. Inspections & Tests should be carried out at least every six months.

Test gases are available for gas detector tests.

All items in kitchens should be regularly be cleaned to ensure dirt and cooking fats do not impair the product performance. **DO NOT** use cleaning sprays.

GUARANTEE:

We guarantee your Product Purchase for 12 months from date of purchase. We shall not be under any obligation to repair, replace or refund any of the above found to be defective in any way due to damage, neglect or unreasonable use.

PANTHERCUB

Gas Monitoring & Automatic Cut -Off System

SPECIFICATION

The Panther Cub system consists of:

- [1] Panther Cub Monitor
- [2] Gas & Detectors (Natural, LP & Carbon Monoxide)
- [3] Heat Detector or Thermal Link
- [4] A Gas Solenoid Valve (Either automatic or manual reset)

The system is designed to monitor the Natural & Carbon Monoxide Gases in air state. The Natural Gas detectors are calibrated to alarm when gas: air mix is 0.5% at the point of the detector. The Lower Explosive Limit (LEL) is 5% Natural Gas in air. The Carbon Monoxide detectors alarm at 50ppm. On Alarm visual and audio indicators will denote alarm state and the gas valve will automatically close thereby isolating the gas supply.

OPERATION

A. Normal State - The system is fully operational & monitoring when the following conditions apply:

- [1] Panther Cub Monitor - Green visual indicator "ON"
- [2] Gas Detector- Green visual indicator "ON"
- [3] Gas Valve - Open

B. Alarm State - On "alarm":

- [1] Panther Cub Monitor - Red visual indicator "ON"
- [2] Gas Detector- Red visual indicator & audio alarm "ON"
- [3] Gas Valve - Closed

C. Resetting the System.

- [1] Ensure that all Natural Gas leaks and all Carbon Monoxide emissions have been rectified. Note: Any work carried out on any gas installations/ appliances must be done by an appropriately qualified CORGI registered person.
- [2] Reset the Panther Cub Monitor using the key switch. Green indicator "ON". For automatic reset valve this will also reset valve. Gas now "ON".
- [3] For manual reset valve - push switch at top of the valve. Gas now "ON".
- [4] Relight all appliances.

**Panthergas Direct Ltd, Unit D4 Seedbed Business Centre, Vanguard Way,
Shoeburyness, Essex, SS3 9QY Tel - 01702 384038 Fax - 01702 384043
sales@panthergasdirect.com**

INSTALLATION - PANTHERCUB

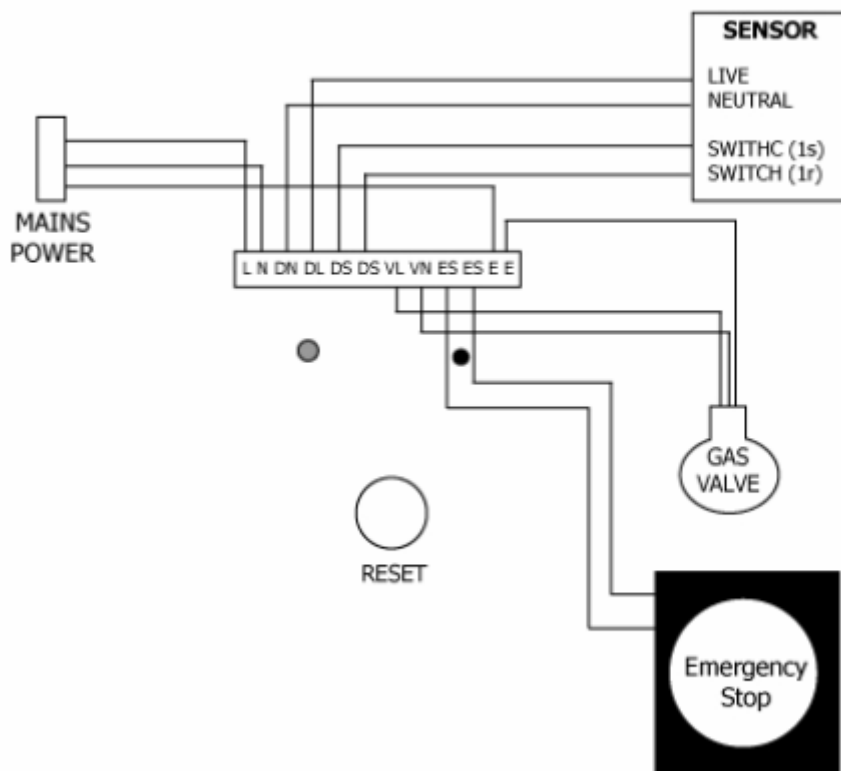

Specification: Model: PA02
Supply Voltage: 240V AC
Operating Voltage: +12DC
Visual Indicators: Green: Power Supply
Red: Alarm Status
Key Switch Operation:
Enable/Reset Size: 120mm x 70mm x 45mm

**Panthergas Direct Ltd, Unit D4 Seedbed Business Centre, Vanguard Way,
Shoeburyness, Essex, SS3 9QY Tel - 01702 384038 Fax - 01702 384043
sales@panthergasdirect.com**

APPLICATIONS

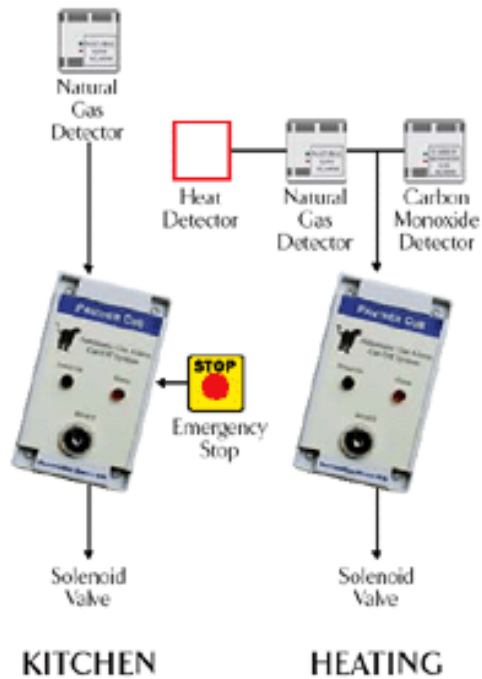

Fire Protection- Heat Detectors and/or Thermal Fusible Links
Gas Detection – Carbon Monoxide, LP Gas and Natural Gas
Emergency Protection- Emergency Stop Buttons
Fire & Gas Monitoring- Boiler Rooms/ Kilns / Kitchens / Residential premises / Gas Pipe
work Monitoring / LP Gas Laboratory Leaks /
Laboratory Prep Rooms / LP Gas Cylinder Monitoring / Student Accommodation

**Panthergas Direct Ltd, Unit D4 Seedbed Business Centre, Vanguard Way,
Shoeburyness, Essex, SS3 9QY Tel - 01702 384038 Fax - 01702 384043
sales@panthergasdirect.com**