

AT-WM1 Water Monitor System 50 to 200mm water meters

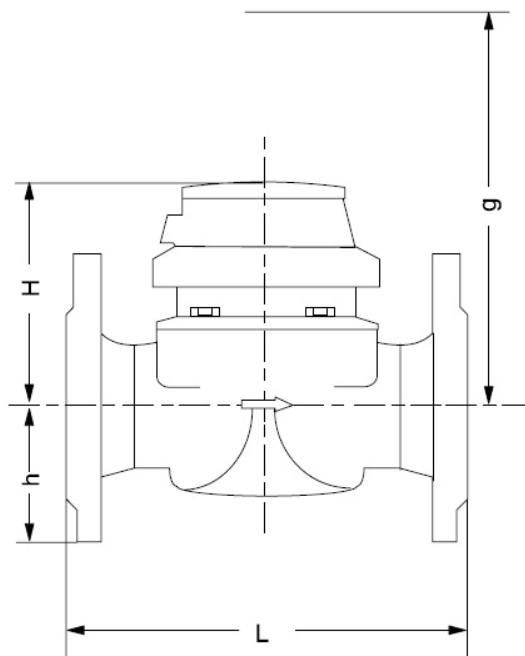

Materials

Body	PN16	cast iron
Measuring element		plastic
Rotorplastic		
We also use		brass
the following materials		stainless steel

Dimensions and Weights

Nominal Diameter		DN		50	65	80	80	100	125	150	200
Size of meter (acc. to EEC)		Q _n		15	25	40	40	60	100	150	250
Dimensions	overall length	L *)	mm	200	200	200	225	250	250	300	350
	height	H	mm	120	120	150	150	150	160	177	206
		h	mm	73	85	95	95	105	118	135	162
		g	mm	200	200	270	270	270	280	356	441
Weights	meter	kg		7.7	10.0	13.6	14.0	18.0	20.5	35.5	50.5
	measuring element	kg		1.4	1.4	3.0	3.0	3.0	3.0	5.5	7.5
	body	kg		6.3	8.6	10.6	11.0	15.0	17.5	30.0	43.0

Important: All information, including illustrations, is believed to be reliable. Users, however, should independently evaluate the suitability of each product for their application. Aquilar Limited makes no warranty as to the accuracy or completeness of the information, and disclaims any liability regarding its use. The only obligations of Aquilar Limited are those in the Aquilar Standard Terms and Conditions of Sale for this product, and in no case will Aquilar Limited be liable for any incidental, indirect, or consequential damages arising from the sale, resale, use or misuse of the product. Specifications are subject to change without notice. In addition, Aquilar Limited reserves the right to make changes – without notification to Buyer – to processing or materials that do not affect compliance with any applicable specification.